

AP - BP - CP PUMP

Installation and Operating Instructions

BOSB Menekşe Cad. No:1 34524 Beylikdüzü
 İstanbul / TÜRKİYE
 Tel: +90 (212) 284 64 00 (Pbx)
 E-mail : info@miksánmotor.com

CONTENTS

1. General information	1
2. Product introduction	1
3. Safety	1
4. Transport and storage	2
5. Installing the product.....	2
6. Operation.....	3

7. Servicing and maintenance.....	3
8. Troubleshooting	3
9. Spare parts.....	4
10. Disposing of the products.....	4
11. EC Declaration of Conformity	4

1. General information

This manual contains the installation, operating and maintenance of the AP, BP, and CP centrifugal pumps with technical features.

Read the manual carefully before installation and using the pump. Keep this user's manual for as long as the pump is in use.

For detailed information, please contact us.

1.1 Safety symbols used in this manual

 Danger of electric shock. Safety sign according to ISO 3864.

 General warning sign according to ISO 3864.

2. Product introduction

AP, BP and CP type pumps are single-stage centrifugal pumps designed to pump coolants. These pumps have semi-open impeller and can be only mounted in vertical position. The pump inlet is immersed into the medium and motor extends vertically above the tank.

2.1 Identification

The nameplate is positioned on the motor and indicates the type model - immersion depth, pump performance data, motor specifications, serial number and production date.

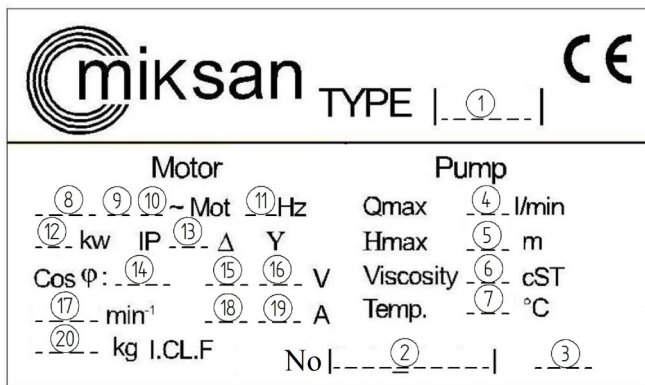

Figure 1. Sample Nameplate

No	Description	No	Description
1	Pump Model	11	Frequency (Hz)
2	Serial Number	12	Rated Motor Power
3	Production Date	13	IP Protection Class
4	Max. Flow Rate	14	Motor Cosφ Value
5	Max. Delivery Head	15	Rated Voltage (V) (Δ)
6	Fluid Viscosity Range	16	Rated Voltage (V) (Y)
7	Max. Operating Temp.	17	Rotational Speed
8	Motor Frame	18	Rated Current (A) (Δ)
9	Motor Pole Number	19	Rated Current (A) (Y)
10	Motor Phase	20	Pump Weight

Table 1. Description of the values in the nameplate

2.2 Pumping medium requirements

Pump Type	AP	BP	CP
Medium	Coolants, water, chemical solutions	Coolants, cooling and cutting oils	
Kinematic viscosity	1...30 mm ² /s	1...45 mm ² /s	1...90 mm ² /s
Medium temperature	0 ... 60 °C		
Allowed chip size	5 mm		6 mm

Pump performances are based on fluid with 1 mm²/s kinematic viscosity and 997 kg/m³ density and tolerance according to ISO 9906:2012 Grade 3B.

3. Safety

It is only the general safety instructions included under this main heading 'Safety' that have to be followed but also the safety instructions provided under the specific headings. Miksan Motor does not accept any liability for damage and injury caused by not applying the directions and instructions in this manual.

Non-compliance with the safety instructions

Non-compliance with safety instructions may pose a risk to the safety of personnel, the environment and the product itself, and also will lead to forfeiture of all rights to claims for damages.

Non-compliance may result in for example, hazards given below

- Failure of important pump/plant functions,
- Failure of recommended maintenance and repair process,
- Exposure of people by electrical, mechanical and chemical hazards,
- Threatening the environment due to leakage of hazardous substances,

◇ Operating Personnel

All personnel participated in the installation, operation, maintenance and inspection of the product must be adequately qualified. Responsibilities, capability and supervision of the personnel must be clearly defined by the plant operator. Moreover, the operator is responsible for ensuring that the contents of the operating instructions are fully understood by the personnel.

◇ Unauthorised modifications and procurement of spare parts

The product has been designed and manufactured with the greatest possible care and any modification may be made to the pump only after consultation with the manufacturer. Using spare parts and accessories authorised by the manufacturer is required to meet safety regulations. Use of non-original parts can invalidate any liability of the manufacturer for consequential damage and may lead to a safety risk.

When operating the pump, the safety instructions contained in this manual, the relevant national accident prevention regulations and any other service and safety instructions issued by the plant operator are to be observed.

◇ During Operation

⚠ If hot/cold machine components involve hazards, they must be prevented against accidental contact.

⚠ Guards for the moving parts (e.g. coupling, fan) must not be removed while the pump is running. Also make sure that guards are never in contact with the moving parts by using proper protection parts

⚠ Any leakage of hazardous (e.g. explosive, toxic, hot) fluids must be drained away to prevent any risk to surroundings.

⚠ Always close the terminal box to prevent hazards caused by electricity.

◇ During Installation, Maintenance and Inspect

Only authorised and qualified personnel may install, maintain and inspect the product and repair electrical components. Observe the local safety regulations.

⚠ Always disconnect the energy supply to the product before installation, maintenance and repairs and secure disconnection.

⚠ Surfaces of a pump can be hot, after continuous operation. Handle the pump with dangerous liquids with the ultimate care. Decontamination of the pump is recommended to prevent hazardous fluids.

On completion of work all safety and protective facilities must be re-installed and made operative again.

Make sure that no one can be near rotating components when starting a pump. Before restarting the machine, observe the instructions listed under 'Start up'.

4. Transport and storage

• Transport the pump in the position as indicated on the pallet or packaging.

• When moving the entire pump assembly by a crane, all ropes must be mounted around the pump

⚠ The lifting capacity of the crane and rope must exceed the weight of the pump. Only qualified personnel are allowed to lift the pump. Do NOT use the terminal box to lift the pump.

• Make sure the pump is stable. Protect pump from damage during transportation. The warranty becomes invalid if damages occur during transportation.

⚠ Do not remove the lever or protection from the pump before the pump is placed and mounted correctly.

• If present, observe the instructions on the packaging.

• All pumps should be stored in a clean dry place. Avoid humidity, dirt and any foreign materials from the pump and do NOT remove the protective plastic pipe ends during storage.

5. Installing the product

5.1 Before installation

• Check the nameplate and performance curve to ensure that the pump meets requirements of your application (Delivery head, flow rate, viscosity etc.).

⚠ Make sure that the product operates within its working range. Only then the product performance is guaranteed.

Check the condition of the pump for any damage that may have occurred during shipping.

Keep the pump vertical and prevent from falling down.

The electrical supply should be verified so the voltage, phase and frequency match that of the pump motor.

5.2 Mechanical installation

Place and install the pump on a flat surface on the top of the coolant tank with the pump body being immersed in the coolant. Immersion depth of the pump should be at least 25 mm shorter than the depth of the tank and minimum fluid level should exceed lower stage of the pump.

The piping must be fully installed and bore diameter have to be chosen according to the discharge of the pump. Flow rate can be adjusted by installing a valve on the piping and on the delivery connection of the pump. Be sure that piping is capable of delivering the hydraulic pressure.

Check the pump stayed out of use for a long time by turning the shaft via hand before installation. Make sure that the suction of the pump is not clogged.

Do not block the air flow through the motor. Make sure that sufficient air can pass the cooling fan (for CP - S type).

Check the direction of rotation of the pump and designated direction on the label on the top of the pump before start up.

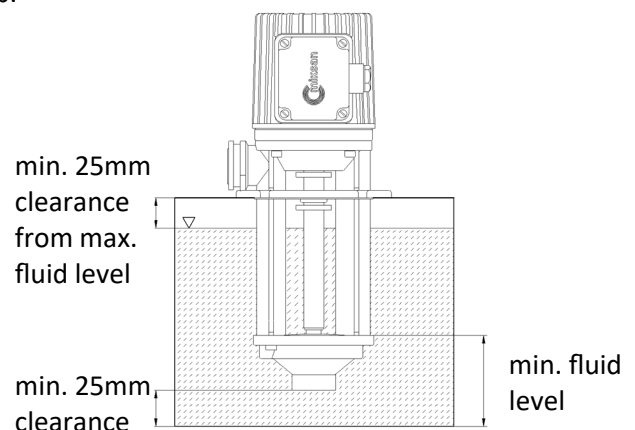

5.3 Electrical connections

Centrifugal pumps consist of air-cooled squirrel cage electric motor and pump parts. Pump side and electrical motor are connected on a single shaft.

⚠ A faulty motor or wiring can cause electrical shock that could be fatal, whether direct contact or conducted through standing water. For this reason, proper grounding of the motor frame to the power supply's grounding terminal is required for safe installation and operation.

⚠ Only trained staff should make the electrical connections of the pump unit. Otherwise, electrical shocks can cause fatal injuries.

- Before running the pump unit, be sure about the electrical connections and connection type. Appropriate voltage level and connection type are shown below.
- Ground terminal of the motor is inside the terminal box. This terminal must be connected to the terminals of the Networks ground terminals.
- Bolts of the connection cables must be tightened. Loose connections cause overheat and faults of the motor.
- Before run the pump, all the mechanical and electrical connections of the pump has been made. Check all of the bolts are fastened tightly.
- Use appropriate fuse and thermal switches etc. to protect the motor damages of the faults
- Always check the voltage level of the pump unit before maintenance and before opening the terminal box.

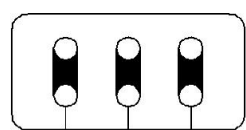

Delta connection (Δ)
3 x 230 V

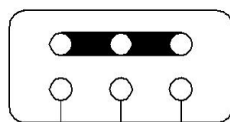

Star connection (Y)
3 x 230 V

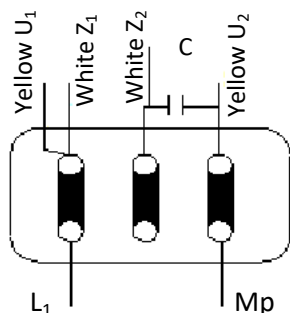

Single-phase connection
1 x 230 V

Wiring diagram can also be found interior of the terminal box cover. All other mechanical or electrical designs are described in the nameplate of the pump.

6. Operation

6.1 Start-up

Install the pump according to 'Installation' heading in the manual.

Switch off the mains and connect the terminals according to 'Electrical connections' heading in the manual. Then close the terminal box.

Check installation and electrical connections steps one more time before starting up the pump.

Briefly start the motor to check the direction of rotation according to the arrow on the top of the motor (By looking through the fan cover that has to turn counter-clockwise for the AP and BP series pumps. For CP, series pumps the fan cover has to turn clockwise.). For three-phases motor, interchange two of the power leads if the direction is incorrect.

Make sure that the temperature of the medium is inside of the designated limits of the pump.

⚠ Check the allowed particle size in the medium and prevent the pump from bigger particles.

6.2 Shut down

- Switch off all the mains.
- Open the terminal box and disconnect all the terminals.
- Evacuate the pump.

⚠ All service work must be carried out by qualified service personnel.

7. Servicing and Maintenance

⚠ Observe the general safety precautions for installation, maintenance and repair.

Do NOT keep the pump immersed in water if it is not in use for a long period. The pump must be stored in dry and clean place. Check the pump shaft by rotating manually before re-installed.

Spare parts are available from the supplier.

8. Troubleshooting

Fault	Possible cause	Remedy
Motor does not start (no motor noise)	Supply failure	Check the power supply
		Check the fuses, terminals and supply leads
Motor does not start (makes noise)	Supply leads failure	See above
	Motor bearing faulty	Replace bearing
Pump does not work (Motor is running)	Low fluid level	Fill up fluid
	Pipe of the machine tool is blocked	Clean the system
	Pump is bound	Turn off power and check the pump shaft by rotating manually
Insufficient pressure and/or flow rate	Pump rotates in wrong direction	Change over two power leads (Valid for three-phase pumps only)
	Pipe of the pump is blocked	Disassemble and clean the clogged area
	Low rotational speed	Check the voltage and power supply
Too much vibration and noise	Bearing faulty	Replace the defective bearing
Power consumption is too high	Too much mechanical friction	Contact to your supplier
	Pump rotates in wrong direction	See above

9. Spare Parts

9.1 Spare part list of AP / BP Pump

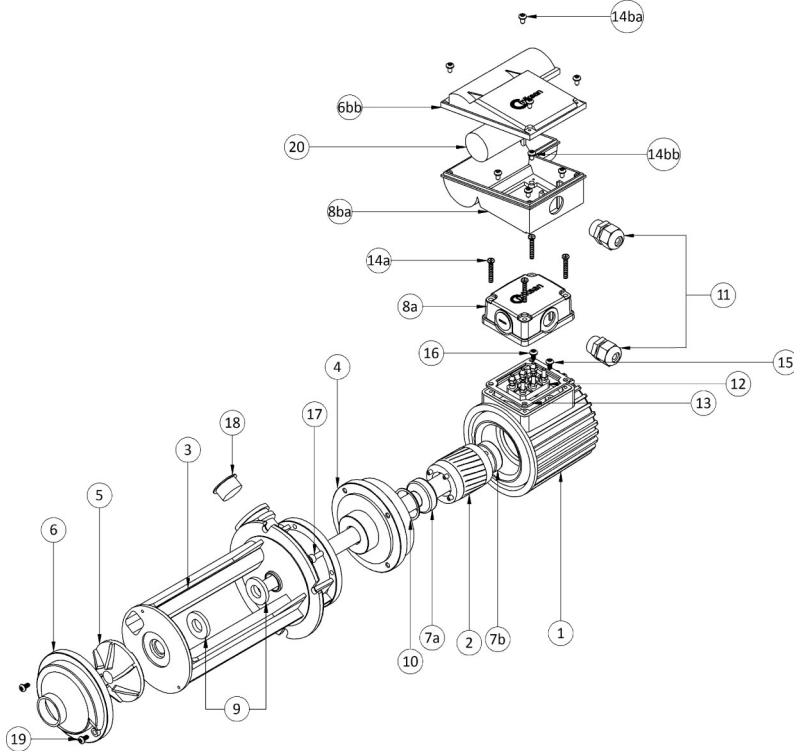

Item	Description	Qty
1	Pump Motor	1
2	Pump shaft with rotor (AISI 1040)	1
3	Pump Body (PP for AP—Aluminium for BP)	1
4	Pump Flange* (AP Pump)	1
5	Impeller (PP for AP—Aluminium for BP)	1
6	Inlet Cover (PP for AP—Aluminium for BP)	1
7a	Front Bearing - 6003 2Z	1
7b	Rear Bearing - 6201 2Z	1
8a	Three-phase Terminal Box	1
8ba	Single-phase Terminal Box (lower part)	1
8bb	Single-phase Terminal Box (upper part)	1
9	Splash Ring	2
10	Wave Spring Washer	1
11	M16 Connector (DIN 46319)	1
12	Terminal (No. 1)	1
13	Terminal Box Gasket	1
14a	Pan Head Screw (for Three-phase Motor) (DIN 7985)	4
14ba	Pan Head Screw (for Single-phase Motor)	4
14bb	Pan Head Screw (for Single-phase Motor)	4
15	Pan Head Screw (Grounding)	1
16	Pan Head Screw (DIN 7985)	1
17	Socket Head Cap Screw (DIN 912)	2
18	Pipe End Plug	1
19	Pan Head Screw (DIN 7985)	2
20	Capacitor (for Single-phase Motors - 8 μ F)	1

9.2 Spare part list of CP Pump

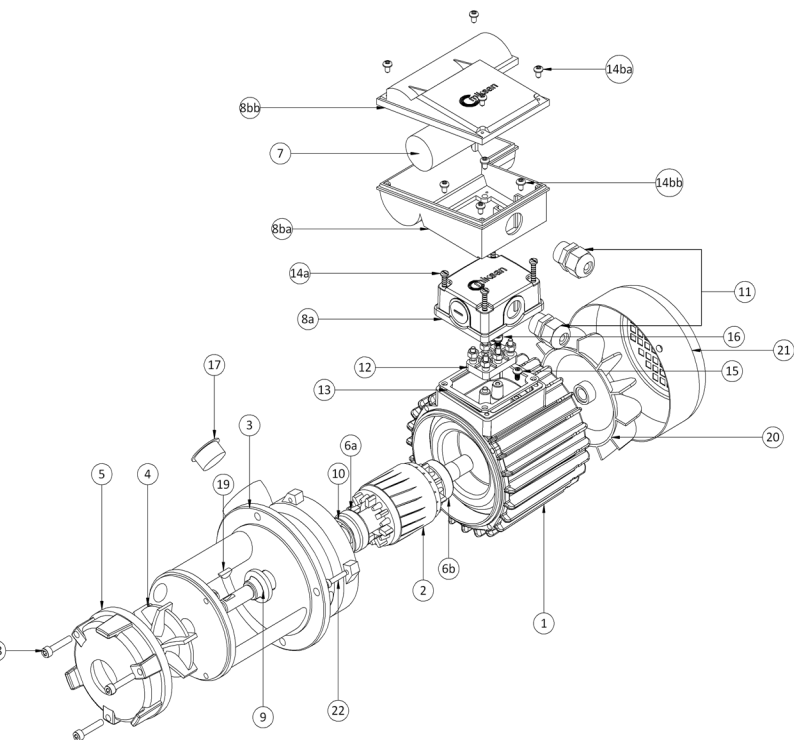

Item	Description	Qty
1	Pump Motor	1
2	Pump shaft with rotor (AISI 1040 - DIN C35)*	1
3	Pump Body (Cast iron)	1
4	Impeller (Polyamide optional Brass)	1
5	Inlet Cover (Polyamide optional Cast iron)	1
6a	Front Bearing - 6003 2Z	1
6b	Rear Bearing - 6202 2Z	1
7	Capacitor (for Single-phase Motors - 8 μ F)	1
8a	Three-phase Terminal Box (Polyamide)	1
8ba	Single-phase Terminal Box (lower part) (Polyamide)	1
8bb	Single-phase Terminal Box (upper part) (Polyamide)	1
9	Splash Ring	2
10	Wave Spring Washer	1
11	M16 Connector (DIN 46319)	1
12	Terminal (No. 1)	1
13	Terminal Box Gasket	1
14a	Pan Head Screw (for Three-phase Motor) (DIN 7985)	4
14ba	Pan Head Screw (for Single-phase Motor)	4
14bb	Pan Head Screw (for Single-phase Motor)	4
15	Pan Head Screw (Grounding) (DIN 7985)	1
16	Pan Head Screw (DIN 7985)	1
17	Pipe End Plug	1
18	Socket Head Cap Screw (DIN 912)	3
19	Woodroof key (DIN 6888)	1
20	Fan (Optional)	1
21	Fan Cover (Optional)	1
22	Socket Head Cap Screw (DIN 912)	2

10. Disposing of the product

This product, all the parts of it and the packaging materials must be disposed according to the local and national regulation for proper disposal.

Prior to its disposal, the pump must be completely drained and decontaminated if necessary.

11. EC Declaration of Conformity

We herewith declare that the design/construction of AP / BP / CP Pump

Complies with the following regulations/standards:

Low Voltage Directive 2014/35/EU

**Directive 2014/30/EU Electromagnetic Compatibility Directive
2006/42/EC on Machinery**